



# Enhancing Security Using GPS-GSM Motorcycle Tracking System

Arnold Mashud Abukari <sup>a\*</sup>, Alhassan Adams <sup>a</sup>,  
Vijaya Kittu Manda <sup>b</sup> and Iddrisu Ibrahim <sup>a</sup>

<sup>a</sup> Department of Computer Science, Tamale Technical University, Ghana.

<sup>b</sup> PBMEIT, Visakhapatnam, Andhra Pradesh, India.

## Authors' contributions

*This work was carried out in collaboration among all authors. All authors read and approved the final manuscript.*

## Article Information

DOI: 10.9734/AJRCOS/2024/v17i6456

## Open Peer Review History:

This journal follows the Advanced Open Peer Review policy. Identity of the Reviewers, Editor(s) and additional Reviewers, peer review comments, different versions of the manuscript, comments of the editors, etc are available here: <https://www.sdiarticle5.com/review-history/115526>

**Original Research Article**

**Received: 02/02/2024**

**Accepted: 06/04/2024**

**Published: 15/04/2024**

## ABSTRACT

Motorcycles are progressively becoming a well-known mode of transportation in Ghana, especially in the northern region. Their affordability and easy movement on our rough roads make them a choice many users prefer. Nonetheless, the increase in the number of these motorcycles brought some concerns connected with safety and security. To resolve these issues, the improvement of the security framework is fundamental. Real-time monitoring is part of the Internet of Things (IoT), which permits distance monitoring. Different tracking technologies such as RFID, Internet tracking, cellphone triangulation, GPS, and other technologies. This research work expects to plan a far-reaching motorcycle security and global positioning framework utilizing an Arduino microcontroller Uno r3, Neo-6mGPS, and GSM SIM800L modules. The GPS module obtains the location area while the GSM module works with interaction between the Arduino Uno and the client's cell phone, showing the area on Google Maps. The framework comprises a locking component and a global positioning framework. The motorcycle's ignition system is controlled by a locking mechanism that enhances protection against theft. Besides, the scarcity of these security systems and the existing motorcycle tracking systems are very costly to purchase and maintain. There is restricting

\*Corresponding author: E-mail: amashud@tatu.edu.gh;

openness for the overwhelming majority of bike users. This prompt is a high pace of bike theft, making recovery challenging. One of the project's goals are to decrease power utilization in the global positioning framework, upgrade GPS following precision, and use SMS as the essential means of communication. This research work adopted the Agile Methodology of designing applications. While this research work presents various benefits, it additionally has limits. These incorporate the expenses of equipment parts. Restricted accessibility of Arduino components in the Ghanaian market and time. Regardless of these restrictions, the exploration attempts to create powerful and open bike security in the Ghanaian market.

*Keywords: GSM; GPS; arduino uno; Google Maps; tracking system.*

## 1. INTRODUCTION

Motorcycles are gradually replacing other modes of transportation as the principal means of mobility, especially in the Northern region of Ghana and other regions. Bikes appeal to people because they are inexpensive, easy to use, and suitable for traversing rugged terrain. However, problems, including theft, accidents, and safety concerns, have been brought about by the rising popularity of motorcycles. It is necessary to develop a motorcycle security system in order to address these problems [1-3].

The Internet of Things (IoT) is a rapidly evolving technology that enables remote device control, including real-time tracking. According to TechTarget, GPS tracking is the process of using the Global Positioning System to observe and follow the movement of an object or entity from a distance. This framework can accurately discriminate between scope, ground speed, and journey path. Contributor at TechTarget, [4]. There are a ton of new developments in tracking technology that are accessible. These include satellite tracking, global position systems (GPS), smartphone triangulation, radio frequency identification (RFID), and internet tracking.

This research aims to create a complete motorbike security system by designing a security system with an Arduino Uno controller that considers the microchip ATmega328P, Neo 6GPS, and GSM Sim800L. The GSM module serves as a bridge that connects the Arduino Uno microcontroller and the client mobile, while the GPS component will be utilized to obtain the location coordinates (Latitude and Longitude). Google Maps will be used to view the location.

This research aims to create a full tracking system by designing a system with an Arduino Uno controller based on a microchip ATmega328P, NEO 6GPS, GSM SIM800L, and a relay. The location coordinates (Latitude and

Longitude) will be obtained via the GPS component, and the user will be able to view the location on Google Maps thanks to the GSM module acting as a bridge between the Arduino UNO microcontroller and their mobile phone.

The locking system and the tracking system are comprised of two devices. The locking system regulates the motorcycle's ignition system, which is secure and will not be vulnerable to theft unless the locking mechanism is engaged [5-9].

Even though motorcycle theft is on the rise, many riders are unaware of how important and useful motorcycle security gadgets can be. Surprisingly, many motorbike owners are ignorant of the substantial influence monitoring systems may have on motorcycle security. Most motorcycles sold in Ghanaian marketplaces rely on mechanical lock and alarm systems that can easily be broken. Making effective security equipment became a rarity. The problems are further compounded because of a lack of awareness [10,11].

The primary issue is the high cost of the motorbike monitoring options now offered in Ghana, which prevents many motorcycle owners from using them. Due to the cost barrier, many Ghanaians cannot fully benefit from the benefits of safeguarding their motorbikes and other valuables, as tracking systems are not widely adopted [12,13].

There are many theft incidents in Tamale and other areas daily due to motorcyclists' poor use of strong security systems. In Ghana's crime investigation processes, it becomes exceedingly challenging to retrieve stolen motorcycles. Motorbikes are typically taken from various locations, such as town centers, schools, hospitals, clinics, and even private and public parking garages. Motorcycles are a practical and reasonably priced form of mobility. Unfortunately, the lack of adequate security mechanisms makes

them easy pickings for burglars. One of the top five crimes in Ghana that receives the most reports is motorcycle theft [14]. This study uses Arduino technology to enhance the motorcycle security system even more.

This research is significant because it has the potential to enhance the current GPS-GSM security system and take into account the particular challenges faced in the Ghanaian context. The security system will prove to be more reliable and accurate in terms of GPS position, power efficiency, serverless operation, and user-friendliness, even for non-techies. This will improve overall safety, asset management, and motorcycle security.

## 2. LITERATURE REVIEW

The increasing need for efficient management in the interest of the public and private sectors has led to a rise in the use of vehicle global positioning systems. The cost of current global positioning systems for cars has limited their use and acceptability in non-industrial nations such as Ghana.

Because of its many potential applications in enhancing fleet management and security, car tracking technology has been thoroughly considered and welcomed in Ghana and other nations. However, there is still a lack of research on the use of motorcycle tracking equipment in Ghana. As a result, there is a deficiency in the literature concerning the creation of effective motorcycle security initiatives.

This literature review aims to connect the material by looking into related initiatives in Ghana and current projects on motorbike GPS frameworks. Although there are not many prior motorcycle positioning frameworks in Ghana, the research will use lessons learned from car GPS framework projects and other similar frameworks that will truly satisfy the client's requirements in Ghana.

The literature evaluation will include various technological advancements, methodologies, data analysis techniques, and framework implementations utilized in automobile and motorbike GPS frameworks in related projects. The review will also deconstruct the challenges encountered and the flaws in the present car GPS frameworks.

A GPS-based vehicle global positioning framework was created by Mohad Hakin Bin

Zohari and colleagues in 2021 to track the whereabouts of a vehicle. The tools utilized for this assignment included an Arduino Mega microcontroller, a SIM 900a GSM module, and a Ublox NEO-6m GPS module.

Effective testing was conducted outside. Nonetheless, the system encountered minimal difficulties indoors because of an overhanging structure and various obstacles that obstructed accurate and direct contact between the GPS and the satellite. The GPS data control module lacked the power to provide precise positions and could not establish faster responses.

Vehicle global position frameworks are quite expensive in Ghana, which results in poor usage and patronage. Specific challenges were noted by Agyemang, Owusu-Manu, and Parn (2015) when implementing vehicle position frameworks in Ghana. The high cost of components, data plans, stakeholder ignorance, and a lack of government involvement in the industry are a few of the challenges. Ghana's sluggish adoption of global positioning systems for cars has been made worse by these challenges.

GA Sekyere [15] developed a low-cost vehicle global position framework in response to these problems. The system is based on GPS and GSM technology, which is widely available and reasonably priced for individuals and businesses of all kinds of usage.

The project employs a website-based framework and a mobile application to notify consumers via email when a vehicle violates a designated geographic border. Users can also remotely track the movement of a targeted vehicle with this framework. However, more research is anticipated to improve the suitability of the global position framework for the least expensive vehicles developed by GA Sakyere in Ghana.

The focus of Buyan, Samuel Ebenezer [16] was on using GPS, GSM, and a microcontroller in Ghana to track and operate a small vehicle through an Arduino-based global positioning framework.

The circuit for the Uno Microcontroller was used to enable communication between the system's components. The GSM module was used to transmit the data comprising the coordinates to the user, while the GPS module was fitted to track the car's location.

The project's primary objective was to develop a robust global position framework at a low cost that can continually track the whereabouts of small vehicles. On the other hand, the technology was utilized to operate the micro vehicle's immobilizer and notify users in the event of theft.

The project's main goal is to create a global positioning system that will allow intercity transportation organizations to track the movement of their buses in real-time. The approach additionally attempts to tackle Ghana's accident and armed robbery problem.

The GPS module provides position and speed data to the microcontroller. The microcontroller manages the coordinates before sending them to the GSM module, which uses the GSM network to send the message (SMS). In addition, the microcontroller handles the bus emergency bush buttons, airbag alarms, and warming. Data regarding the position is shown on the microcontroller LCD screen.

The system has many benefits for drivers, passengers, and intercity travel. It continuously sends data to an effective fleet management system for improved planning that considers route modifications. The system responds quickly to accidents and robbery incidents in case of emergency.

In general, the project plan uses GPS and GSM technologies to strengthen vehicle security systems between intercity transport organizations in Ghana further. P. B. S. Fleischer and Atso Yao Nelson.

However, Archie Pachica and colleagues developed a motorcycle tracking system to address the problem of motorcycle theft and recovery. When it is relocated without permission, the system can alert the owner. The creative system and computer-based intelligence enable a simple and quick recovery. Thanks to the system, the user could take a picture of the burglar and remotely turn the bike on or off from a distance. The system includes GPS, GSM, camera, and Arduino microcontroller modules. To facilitate quick and simple contact between the user and the system, a mobile application was created.

They discovered that the alarm system and immobilizer deterred criminals, which led to a significant decrease in motorcycle theft following

the construction and installation of the security system.

The study highlighted some of the difficulties encountered in creating a resilient system. The system becomes more expensive for small and medium-sized businesses due to the camera upgrade. The evaluation suggested further research on the system's affordability, feasibility, and adaptability to handle infinite monocycles.

The study generally assumed that adding a camera might make the existing Arduino-based motorcycle tracking system more helpful. The technology can provide real-time data and images of the area in progress, which may be used in many applications to support decision-making. The study recommended more research on the framework's affordability and adaptability to improve its transparency and usability.

In a 2017 study, Supriya et al. [17] used an Arduino-based vehicle monitoring system to keep an eye on a vehicle on Indian public transportation. The evaluation aimed to enhance public transportation's efficacy, safety, and security by providing ongoing information on vehicle transit.

A GPS module, a GSM module, and an Arduino Uno microcontroller were employed in the study project. The vehicle's location was ascertained using the GPS module, and the location coordinates were transmitted to the server for analysis and storage using the GSM module. In the event of theft or unauthorized usage, the relay module controls the immobilizer on the car.

In order to assess the system's performance, it was mounted on public transit vehicles, and the results were collected and examined. According to the study, the system provides reliable and consistent location data and efficiently tracks the movements of public vehicles.

The ability of the research to raise public transportation safety standards was its main goal. The technology can monitor driver behavior and identify risky driving behaviors, such as excessive speeding or sudden stops. When an armed robbery or unauthorized use occurs, the technology can also be used to immobilize the car.

Nonetheless, the study identified a few challenges associated with the tracking system's adoption. A primary obstacle was the lack of

technical knowledge among users, which made system setup and maintenance challenging.

Finally, the research made the assumption that using an Arduino-based tracking system might increase public transportation's effectiveness and safety. Real-time data on vehicle movement is available from the system and can be utilized to inform decisions. The assessment made additional recommendations for scalability and integration with other technologies to increase the system's use.

In 2020, Budi Artono and associates conducted research in Indonesia on applying an Arduino-based motorbike security system. The security system used a microcontroller, GPS, and GSM transmitter to track the movement of the bikes and provide further control over the system in the event of theft.

Thanks to the security architecture, they could inspect the bike almost constantly and send out notifications for faster action. The vibration sensor's ability to distinguish between unauthorized access to the bike and other areas of strength adds an extra layer of security and safety, perhaps reducing the likelihood of motorbike theft.

The Arduino-based global positioning system was considered a capable and affordable motorbike security solution in Indonesia. The analysis claims that drivers and motorcycle owners can use the structure to lower nationwide theft rates.

Finally, after reviewing the literature, the researcher discovered various issues with current global positioning frameworks in Ghana and other nations. The main issues noted are the cost of expensive components and monthly subscription fees for tracking services, which might hinder small and medium-sized firms from using these systems. Furthermore, security concerns might prompt resistance among motorbike users who feel uncomfortable with steady checking of their whereabouts and movement.

The potential vulnerability of GPS to tampering by thieves is another problem. Current security systems are weak since they do not have enough security measures. Thieves can readily disable or remove them. Furthermore, most security systems rely on the vehicle's battery, which poses a serious issue because of the

system's short battery life and the need for frequent battery replacement or recharging.

The researcher intends to use Arduino's capabilities to create a better motorcycle security system that will work for Ghanaian riders to overcome these obstacles. The Arduino platform is ideal for this project because of its affordability and adaptability. High-level components will be incorporated into the suggested structure.

Betty Blankson researched anti-theft vehicle GPS utilizing LoRa Innovation in 2022 to increase the efficacy and efficiency of vehicle monitoring systems in Ghana.

The researcher employed parts like an Arduino Nano 33BLE Sense, a GPS module, and a LoRa transceiver to accomplish the goals. For this experiment, a temperature sensor was installed on the Nano 33 BLE to identify any odd temperature variations within the car. The primary controller will be able to receive warning signals from this device. When the car is parked, the sensor is also utilized to detect movement around it.

According to the research's findings, the tracking system that was created may keep an eye on drivers' performance by cutting down on fuel use and optimizing routes.

Finally, the research identified a few challenges associated with developing and implementing Arduino-related projects in Ghana; the inaccessibility of Arduino parts in the Ghanaian market may impede efforts to strengthen the security framework. This will significantly increase the cost of the framework for Ghanaian individuals and small and medium-sized businesses.

Following a literature survey, several problems with the current motorbike monitoring systems were discovered for this study. The primary issue is that small and medium-sized businesses may be deterred from using these frameworks by the monthly membership costs and the high cost of the current tracking devices. Motorcycle owners may also feel unhappy about the location and movement monitoring due to privacy issues.

## 2.1 Arduino IDE

Arduino Integrated Development Environment (IDE) allows users to write and upload code to Arduino hardware. It is a cross-platform

application that is written in the Java programming language. The Arduino IDE includes a simplified version of the C++ language. The Arduino IDE software is available for Windows, MacOS, and Linux users. This software is simple, easy, and convenient due to its robust nature. It has code editing functions and is well-equipped with a list of libraries that provide extra functionality for use in sketches, allowing users to connect and control sensors.

The Arduino IDE supports the C and C++ languages using special rules of code structuring.

This current version (Arduino IDE 2.2.1) is faster and even more powerful, with a modern editor and a more responsive interface. It features autocomplete, code navigation, and even a live debugger. Other old versions include Arduino PLC IDE 1.0.3, Arduino IDE 1.8.19, Arduino IDE:1.8.18, Arduino 1.0.x, and Arduino 1.5.x beta [18].

## 2.2 Arduino Tools

You can write codes and upload them to your board with Arduino web editor or desktop software. Another option is to use the Arduino IoT cloud web platform [19]. This programming language is used because it is compatible with Arduino components in terms of programming. Arduino IDE tool is a language used to program microcontroller boards such as sensors, actuators, and other devices connected to the board. The software is easy to use for beginners and non-programmers.

## 2.3 The Proposed System

The proposed motorcycle global positioning System (GPS) framework presented in this research paper is intended to give motorbike owners real-time location information. It permits users to monitor their motorcycles' current position and control motorcycles remotely through SMS. The system receives the GPS location of the motorcycle and displays it on Google Maps. Users can monitor the motorcycle movement, set geofences, and receive alerts for unauthorized movements. The GPS module continuously receives satellite data (Latitude and Longitude) through the receiver. The Arduino Uno r3 receives data on its Rx (Receiver) pin, which is connected to the Tx pin of Neo 6gps. Processing involves parsing the NMEA sentences sent by the GPS module and

performing additional tasks like data filtering, calculating the speed, and performing other logical operations based on the algorithm in the module. The microcontroller sends the processed GPS data to the Sim800L module over the Tx (Transfer) pin which is used to establish a connection with a cellular network inserted in the GSM micro-SIM slot.

In emergencies or security concerns such as unauthorized use or theft, users can remotely activate the relay module through a mobile phone by issuing commands through text messages. The single-channel relay module is connected to the Arduino pin4, which cuts off power to the motorcycle's ignition system.

## 2.4 Proposed System Components

The hardware requirements of a motorcycle tracking system are the physical components and devices necessary to build the system.

### 2.5 Microcontroller

The microcontroller acts as the processor for the tracking system and is responsible for data processing, decision-making, and communication with other interconnected modules.

### 2.6 UNO R3

Arduino UNO is a microcontroller board based on the ATmega328P. It is made up of 14 digital input/output pins. It has a processor speed of 16MHZ ceramic resonator, a USB connection, and a power jack. This board contains everything needed to support the microcontroller. The component can be connected to a computer with a USB cable for easy programming. It supports an AC-to-DC adaptor or battery to power up.

### 2.7 GPS Module

This part obtains the latitude and longitude of the motorcycle's current GPS coordinates. The GPS receiver module is a low-cost, fully integrated device featuring an inbuilt patch antenna. The GPS receiver tracks up to 12 satellites through the serial command interface and offers conventional raw NMEA0183 (National Marine Electronics Association) strings or user-requested data. In addition to providing the current time and date, this device can be used for various tracking applications, such as fleet management, auto-pilot, mapping, navigation, speed, and trip patterns (Paralax, 2015).

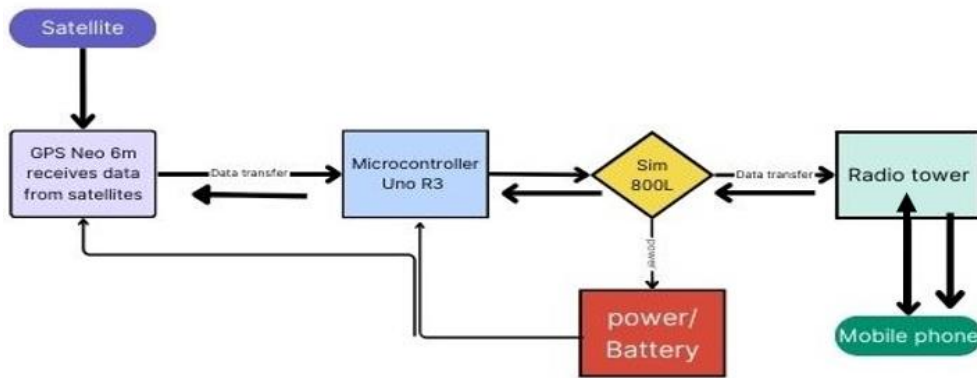

Fig. 1. Block diagram of the proposed system



Fig. 2. Arduino UNO R3



Fig. 3. Neo 6M GPS module

The receiver contains a single red LED to indicate the system status. The LED is located at the lower left corner of the module.

The LED shows two states of the receiver:

- i. Blinking: (both fast and slow). This status indicates device searching or no satellite fixed acquired.

- ii. Solid [not blinking]: This status indicates the satellite was successfully acquired. A minimum of three to four satellites is required before the module will begin to transmit valid GPS coordinates.

When the GPS is in a new location, the receiver may take up to five minutes or less to get at least four satellites to make fixed geo coordinates.



## 2.8 GSM

Global System for Mobile Communication (GSM) is a second-generation (2G) mobile network widely used worldwide for mobile communication. The GSM component is designed to use a MicroSIM slot that allows users to fit a SIM. This unique number is used to identify a SIM holder when it is active on a network. This device is also made up of a unique hardware number called IME number, which is different from each other hardware component.

This project uses a SIM800L module, a Quad-band GSM/GPRS cellular chip from SimCom in SMT type. Sim 800L supports Quad-band frequency. It works on frequencies 850MHz, 900MHz, 1800MHz and 1900MHz. It can transmit and receive voice, SMS, and data information with low power consumption. The operation voltage is from 3.4v to 4.4v, which makes it ideal to operate with a Lipo battery supply. This module type will not work properly if the voltage is not up to the required input and will also be damaged when the voltage exceeds the required voltage. This means that one must not connect it directly to Arduino 5v output [20].

Much attention was needed on this part of the project to avoid damaging this component. A DC-DC step-down converter regulated all components' fixed and stable voltage.

## 2.9 Led Status Indicators

The SIM800L Module's LED is situated on the uppermost right corner edge. When the LED is turned on, it will blink in three distinct ratios to display the three different cell network conditions.

**Blink every second:** The GSM module is operational but not yet linked to a cellular network if the LED blinks once every second.

**Blink every 2 seconds:** An active GPS data connection is shown by an LED blinking every 2 seconds.

**Blink every 3 seconds:** The module has established contact with the cellular network and is prepared to send or receive voice or SMS messages when the LED blinks every 3 seconds.

## 2.10 Antennas

SIM800L comes with two types of antennas. The Helical GSM and the PCB antenna. The antenna gives the module the required signal for the network to operate.

## 2.11 DC-DC Buk Converter

This is an LM2596 DC-DC Buk converter step-down Power Supply Module. This module can be used in various DC applications, including batteries, power transformers, DIY power supplies, and industrial equipment. It can support an input voltage range of 0-40v DC with an accuracy of +-0.05V. It can be used to convert 12 to 3.4, 12 to 5V, and 24 to 5V, among others, and adjustable output version.

In this research paper, the LM2596 transforms and regulates current from the microcontroller Vin and Gnd pins because of its high accuracy in power voltage regulation. The step-down converter was further tested to regulate the output voltage to 4.4v output to avoid power issues to the GSM and GPS modules.



Fig. 4. SIM800L front and back



## 2.12 Relay Module

A relay is a small current signal control equipment that is commonly used to control high-power electric modules through SMC. It is widely used to make smart home projects and IoT projects requiring power cut-offs.

## 2.13 Single Channel Relay Module

A single-channel relay is an electronic switch that can control a low-power electrical signal, such as the output from an Arduino microcontroller. A Relay Board 5v 1-Channel single relay module was employed in this project. This module uses two LED status indications: onboard power indicator (green) and relay indicator (red) Circuit Digest [21].

## 2.14 Power Supply

The power supply is significant for all electronics. AC adapter was used to supply electrical current to the system. A supported AC adapter 220V

input to 9V output adapter was employed to power up the Arduino microcontroller, which can support up to 9V – 2Amps current supply.

## 2.15 Procedure and Steps

1. The circuit diagram was designed using an online circuit diagram
2. Assembly components based on the circuit diagram onto a perforated PCB board.
3. Insert the GPS module into the right wiring diagram
4. Insert the GSM module into the right wiring diagram
5. Fix the DC-DC power converter
6. Power up with the external power AC adapter to make sure that the system is wired correctly and all the components are functioning

A complete circuit diagram of the GSM-GPS security system was simulated from the Circuit.IO online circuit diagram.



Fig. 5. DC-DC LM2596 Buck Converter

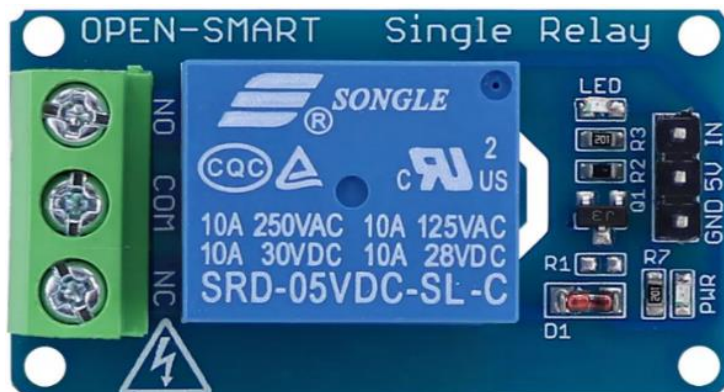

Fig. 6. A Relay board 5v 1 – Channel single relay module



Fig. 7. Ac adaptor

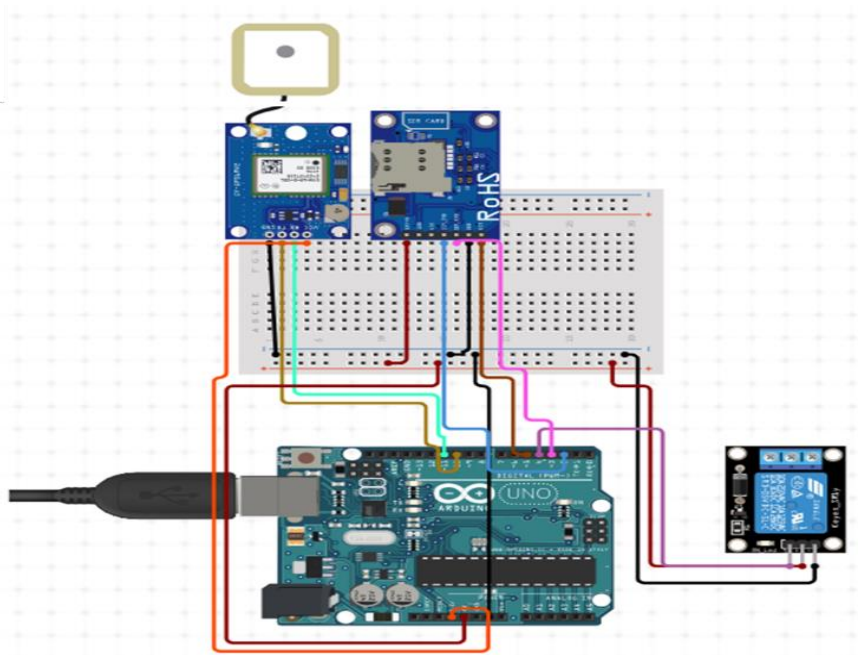

Fig. 8. A complete circuit diagram of the GPS-GSM motorcycle security system

After assembling all the components, the system was powered up and tested to ensure that all the components were functioning properly. Fig. 9 is a pictorial representation of the system.

### 2.16 Proposed System Setup

The system was connected to a computer using a USB cable to program it. The research work used Arduino IDE software to design and test the system. To ensure that the sim800L module, which helps with communication, was working properly, a test was carried out utilizing "AT"

commands to make sure that the module was working properly. A test was carried out on both sending and receiving messages. Fig. 10 shows the test results of the sim800L module, which produces a clear and good signal for the project.

The GPS module was also connected through a serial connection to receive GPS signals that would determine the location of the motorcycle. Different tests were carried out to observe the signals received from the satellite. The function in the Arduino sketch script in Fig. 11 was used to test the GPS Noe 6m readings.

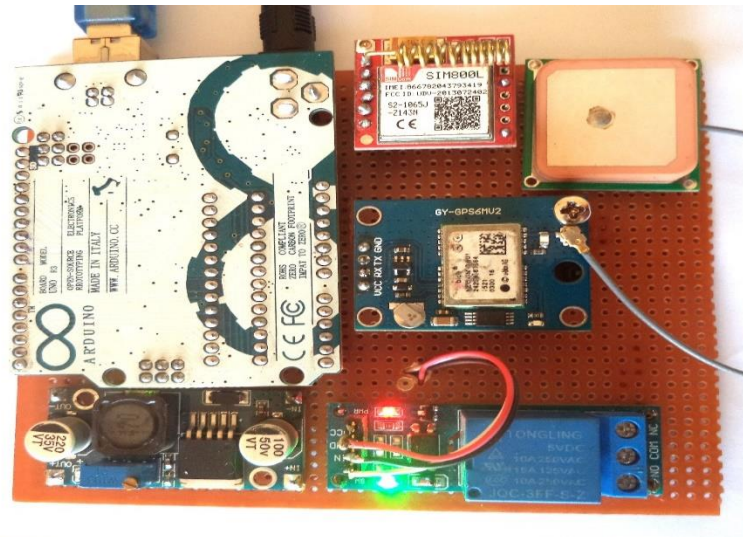

Fig. 9. A pictorial representation of the assembled components



Fig. 10. GSM test result captures from Arduino sketch using AT commands

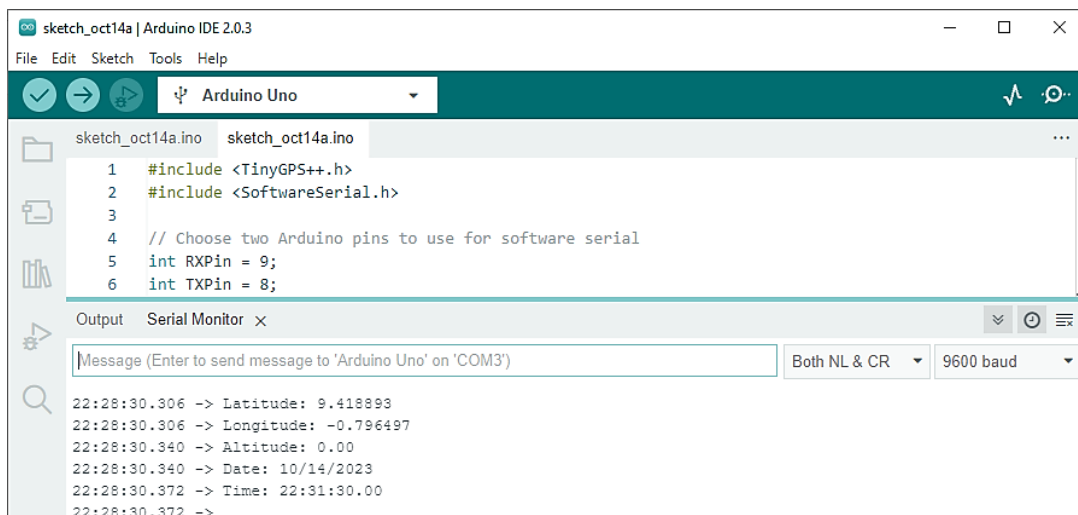

Fig. 11. Captured in the serial monitor of the Arduino sketch

In the implementation of the project, a control system was first developed to control the bike from a distance. This idea is to allow users to control the motorcycle remotely. The system was later developed by integrating the GPS commands to form the motorcycle security system.

The components are connected serially to communicate to form the system. The GPS receives location data from satellites and sends it to the microcontroller which processes the data. Then, the microcontroller sends the refined location information to the GSM receiver, which sends the requested information to the user's mobile phone.

The system was programmed to receive commands through text messages.

These messages were turned into instructions to control the different parts of the system.

The system is programmed to send and receive data and respond to commands. This makes it easy for users to interact with the system, even though it is a system where people talk directly to the system.

Further testing and fixing processes were carried out to make sure the system worked perfectly. Troubleshoot problems and made sure everything was in order. One tricky part was getting the sim800L component and the Neo 6m module to work together because they had different voltage requirements when sending and receiving information.



```
1
2 #include <SoftwareSerial.h>
3 #include <AltSoftSerial.h>
4 #include <TinyGPS++.h>
5
6 #define ignition_switch 4
7
8
9 #define rxPin 3
10 #define txPin 2
11 SoftwareSerial sim800(rxPin, txPin);
12
13 AltSoftSerial neogps;
```

Fig. 12. Library and serial communication setup

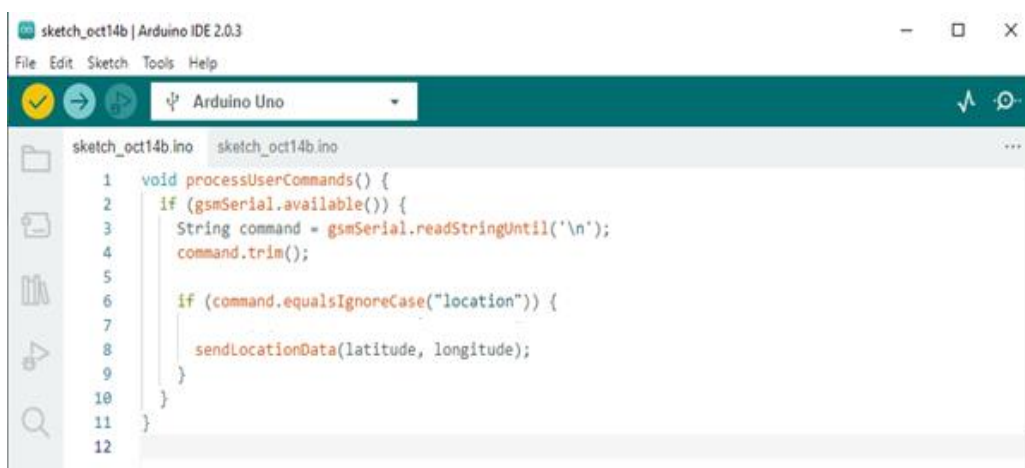

```
1 void processUserCommands() {
2   if (gsmSerial.available()) {
3     String command = gsmSerial.readStringUntil('\n');
4     command.trim();
5
6     if (command.equalsIgnoreCase("location")) {
7
8       sendLocationData(latitude, longitude);
9     }
10  }
11 }
12 }
```

Fig. 13. Location setup



### 2.17 Proposed System Testing Results

Testing the GPS took a little time because sometimes the hardware component took a little time to get a fixed location before sending the

location information. The result obtained after this test yielded a positive outcome. A message containing the Google Maps website and GPS positions was received to redirect users to view the location on Google Maps.

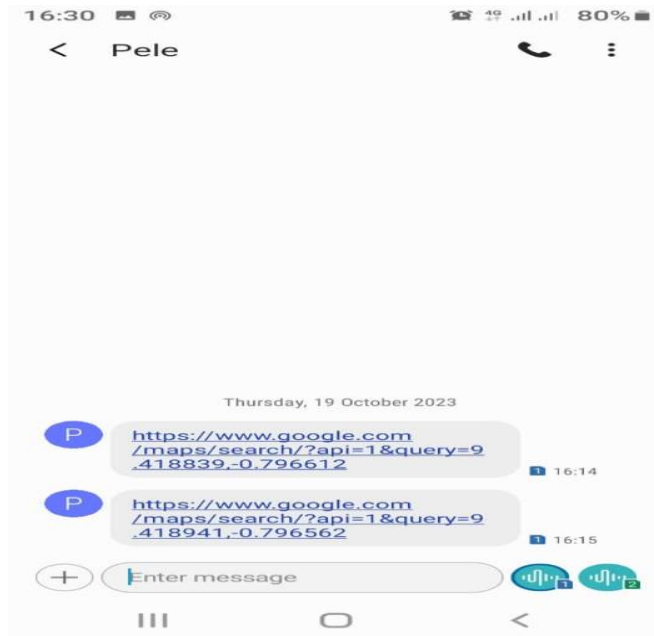

Fig. 14. Received messages from the tracking system

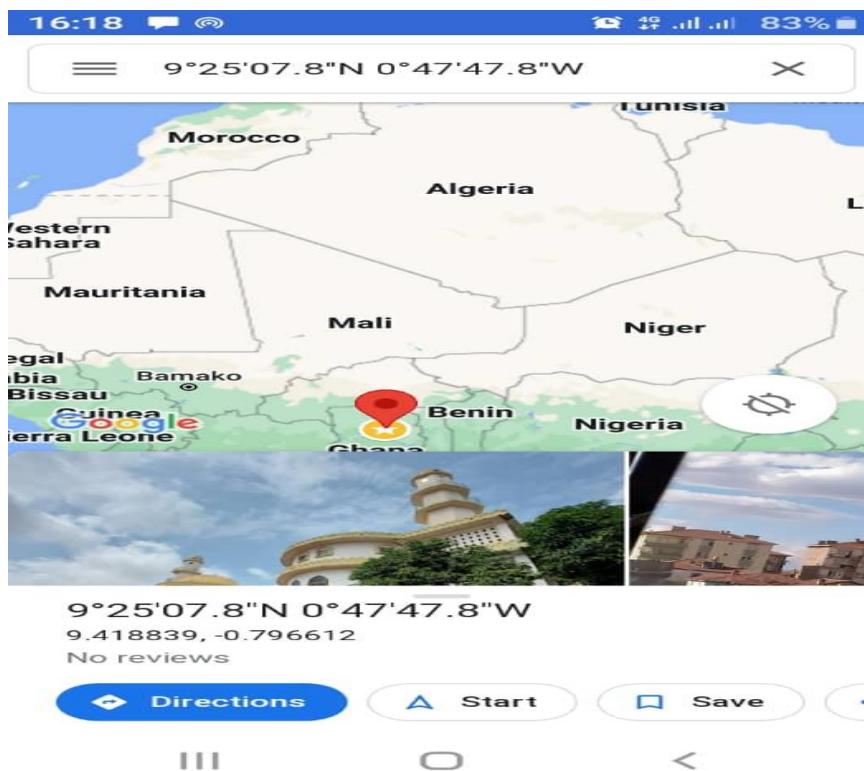

Fig. 15. Google Maps location from the tracking system

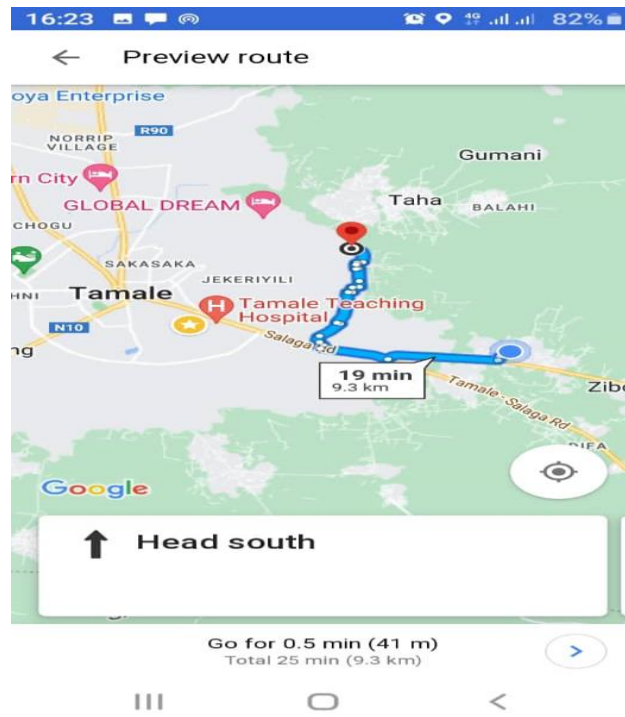

Fig. 16. Data is required to open the webpage on Google Maps

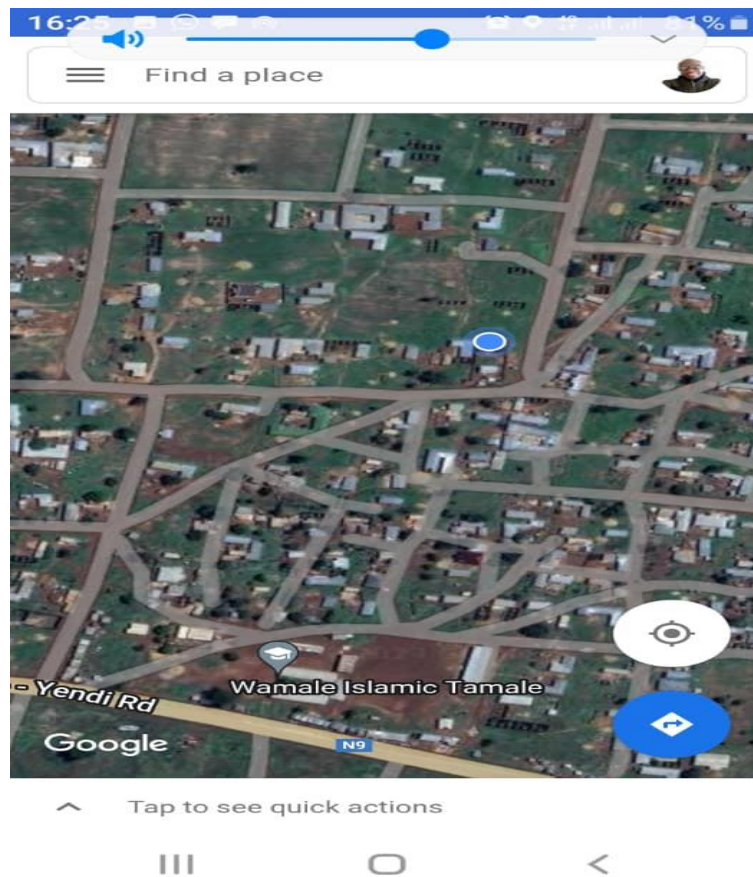

Fig. 17. View of the location, both satellite view and map view



The user can open the message to view the position on Google Maps. At this point, data is required to open the webpage on Google Maps.

### 3. CONCLUSION AND RECOMMENDATIONS

The security framework was designed and implemented using the Arduino components. The security framework allows users to monitor the location of their motorcycles constantly. The main components to implement this security system are Arduino microcontroller Uno r3, Sim800L, Neo 6m GPS, and a relay. This research paper developed a motorcycle security system that can give the position of a motorcycle's location and allow a user to send commands to turn the ignition ON and OFF and even LOCATE it. This user-friendly security framework allows a user to have complete control over the motorcycle. The system is straightforward to use and can be managed by users. This security system is affordable, will help recover stolen motorcycles, and will go a long way in reducing motorcycle theft in our country. There is no technology without limitations. The GPS takes time to connect to the satellite and may vary due to weather conditions. The GSM device in the security system can only respond to messages when there is a network. In places with a poor network, the system may not respond to commands as expected. The system will not respond to commands in the event of a power cut-off.

This research recommends that Artificial intelligence (AI) be added to predict when motorcycles may need maintenance or detect unusual activities and Investigate the ethical concerns of tracking systems.

### COMPETING INTERESTS

Authors have declared that no competing interests exist.

### REFERENCES

1. Saurabh SC, Vivek RK, Suryawanshi YA. ARM Hardware Platform and Vehicular Monitoring and Tracking, International Conference on Communication Systems and Network Technologies. 2013: 757-761.
2. Ali ZA, Mehmet AK. An Internet-Based Interactive Embedded Data- Acquisition System for Real-Time Applications",IEEE Transactions on instrumentation and measurement. 2009;58(3):522- 529.
3. Chih-Ching LI, Chh-Chen Wu HS. Liu MY, Tseng. A Real Time GPRS Surveillance System using the Embedded System. 2003:1228-1234.
4. TechTarget Contributor. The concept of GPS Navigation system; 2022: Available:https://www.techtarget.com/whatis/definition/GPS-tracking
5. Archie Pachica. Motorcycle theft prevention and recovery security system; 2017 Available:https://www.researchgate.net/publication/322483066\_Motorcycle\_theft\_prevention\_and\_recovery\_security\_system
6. Betty Blankson. conducted a study on Anti-Theft Vehicle Tracking System Using Lora Technology; 2022. Available:https://air.ashesi.edu.gh/server/api/core/bitstreams/a3c169a5-a5e0-499e-a2e3-5e1e3633f4b8/content
7. Budi Artono Et al. Motorcycle Security System using SMS Warning and GPS Tracking; 2020. Available:https://www.researchgate.net/publication/341046746\_Motorcycle\_Security\_System\_using\_SMS\_Warning\_and\_GPS\_Tracking
8. Circuit IO; 2023. Available:https://www.circuito.io/app?components=512,11021,316349,975601,3061987
9. Fleischer PB et al. Design and development of GPS/GSM based vehicle tracking and alert system for commercial inter-city buses. Available:https://ugspace.ug.edu.gh/handle/123456789/26693
10. Mohd Hakin Bin Zohari and others GPS Based Vehicle Tracking System. retrieved from:https://www.researchgate.net/publication/352559892\_GPS\_Based\_Vehicle\_Tracking\_System
11. Wheeb AH. Performance Analysis of VoIP in Wireless Networks, International Journal of Computer Networks and Wireless Communications (IJCNC). 2017;7(4): 1-5.
12. Ming Lu a, Wu Chen b, Xuesong Shen, Hoi-Ching Lam, Jianye Liu C. Positioning and tracking construction vehicles in highly dense urban areas and Building construction sites. 2007:647-656.
13. Xing Jianping, Zhang Jun, Cheng Hebin, Li Changqing and Shi Xiaohui. GPS Real Time Vehicle Alarm Monitoring System

- Base on GPRS/CSD using The Embedded System. 2006:1155-1158.
14. Abu Mubarik. Top 5 most reported crimes in Ghana; 2016. Available:<https://www.pulse.com.gh/ece-frontpage/crimes-in-ghana-top-5-most-reported-crimes-in-ghana/xbscnlf>
  15. GA Sekyere. 2019 Available:<http://hdl.handle.net/20.500.11988/534>
  16. Bunyan, Samuel Ebenezer. Implementation of a GPS Tracking System and a Remote Control Interface for a Mini-Vehicle; 2019. Available:<https://air.ashesi.edu.gh/server/api/core/bitstreams/5dccc5-0b08-4d83-a0af-add27bc57c5f/content>
  17. Supriya AS. et al. Vehicle Tracking System for School Bus by Arduino; 2017. Retrieved:[https://www.academia.edu/37777138/Vehicle\\_Tracking\\_System\\_for\\_School\\_Bus\\_by\\_Arduino](https://www.academia.edu/37777138/Vehicle_Tracking_System_for_School_Bus_by_Arduino)
  18. Arduino. Arduino IDE V1 basics; 2023. Available:<https://docs.arduino.cc/software/ide-v1/tutorials/arduino-ide-v1-basics> <https://www.arduino.cc/en/software>
  19. Siddhesh Shinde. Pros and Cons of the Aduino programming language; 2023. Available:<https://emeritus.org/blog/coding-arduino-programming-language>
  20. Electroduino; 2022. Available:<https://www.electroduino.com/sim800l-gsm-module>
  21. Circuit Digest; 2023. Available:<https://circuitdigest.com/microcontroller-projects/interface-single-channel-relay-module-with-arduino>

© Copyright (2024): Author(s). The licensee is the journal publisher. This is an Open Access article distributed under the terms of the Creative Commons Attribution License (<http://creativecommons.org/licenses/by/4.0>), which permits unrestricted use, distribution, and reproduction in any medium, provided the original work is properly cited.

*Peer-review history:*  
The peer review history for this paper can be accessed here:  
<https://www.sdiarticle5.com/review-history/115526>